

High-Capacity Sensitive Check Valves

CF Series

Introduction

High-Capacity Sensitive Check Valves, also known as exhaust check valves, feature minimal cracking pressure and high capacity. These valves are typically installed on the exhaust side of a vacuum pump to prevent air from entering the system during pump shutdowns or malfunctions.



Features

- ⊙ 316 SS body, equipped with FKM O-ring
- ⊙ Minimal cracking pressure, large orifice, and high capacity
- ⊙ Non-adjustable cracking pressure
- ⊙ KF Vacuum Flange Port

Technical Data

Nominal Cracking Pressure psig (mbar)	0.22 (15)	0.36 (25)	0.73 (50)	0.91 (63)	1.02 (70)
Cracking Pressure Range psig (mbar)	0.1~0.25 (6.9~17.2)	0.27~0.4 (18.6~27.6)	0.6~0.75 (41.4~51.7)	0.7~0.95 (55.2~65.5)	0.85~1.05 (62.1~72.4)
Reseal Pressure psig (mbar)	Back Pressure ≤0.1 (6.9)	Inlet Pressure ≥0.2 (13.8)	Inlet Pressure ≥0.4 (25.6)	Inlet Pressure ≥0.5 (41.4)	Inlet Pressure ≥0.65 (44.8)
Max. Working Pressure psig (bar)	145 (10)				
Working Temperature Range °F (°C)	32 ~ 248 (0 ~ 120)				
Wetted Surface Roughness µin. (µm)	Mechanical Polishing Ra 16 (0.4)				
Process Specification	FC-01 or FC-02				
Flow Coefficient (Cv)	14.4				
Leak Rate (Helium)	Internal	<1x10 ⁻⁷ std cm ³ /s			
	External	<5x10 ⁻¹⁰ std cm ³ /s			

Standard Materials of Construction

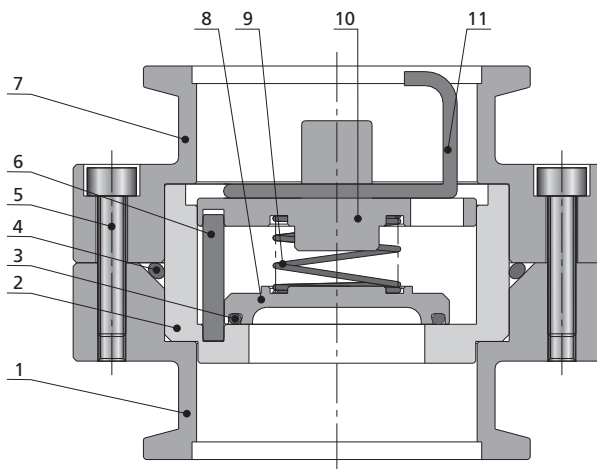

Item	Component	Material Grade
1	Inlet Body	316 SS
2	Sleeve	316 SS
3	O-ring	FKM
4	O-ring	FKM
5	Screw	Stainless Steel
6	Round Pin	Stainless Steel
7	Outlet Body	316 SS
8	Poppet	316 SS
9	Spring	304 SS
10	Seat	316 SS
11	Limit Bracket	316 SS

Dimensions and Ordering Information

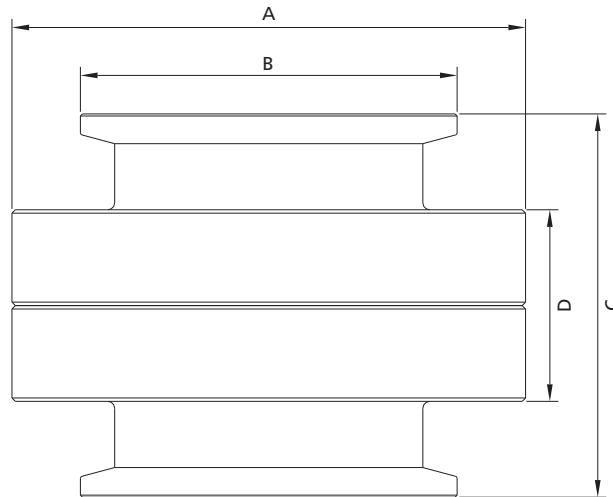

Basic Ordering Number	Connection Type	Orifice in. (mm)	Cv	Dimensions, in. (mm)			
				A	B	C	D
CF□□-KF40-□□-□□-□□	KF40	0.98 (25)	14.4	2.95 (75)	2.17 (55)	2.2 (56)	1.1 (28)

Note: Dimensions are for reference only and are subject to change. For other dimensions, please contact FITOK Group or our authorized distributors.

Ordering Number Description

CFSS - KF40 - 25 - F2

Series	Body Material	Connection Type	Nominal Cracking Pressure Designator		Process Specification
CF	SS 316 SS	KF40 Vacuum Flange Port	15	0.1~0.25 psig (6.9~17.2 mbar)	FC-01
			25	0.27~0.4 psig (18.6~27.6 mbar)	F2 FC-02
			50	0.6~0.75 psig (41.4~51.7 mbar)	
			63	0.8~0.95 psig (55.2~65.5 mbar)	
			70	0.9~1.05 psig (62.1~72.4 mbar)	

Notes:

1. "Ordering Number Description" is a reference to understand the combination rules of FITOK product part number. Not all combinations are available. For any questions, please contact FITOK Group or our authorized distributors.
2. Check valve is designed with unidirectional flow path, it can't be used as safety relief valve.