

Condensate Pots and Vessels



Condensate Pots

Features

- ⦿ Suitable for application with water, oil or gas
- ⦿ Chambers are made from seamless pipe and weld caps
- ⦿ Full-penetration gas tungsten arc -weld construction to ensure great strength and leak-tight performance
- ⦿ Five pressure ratings available

Technical Data

- ⦿ Working pressure up to: Class 2500 as per ASME B16.34
- ⦿ Socket weld connection as per ASME B16.11
- ⦿ Butt welding ends as per ASME B16.9
- ⦿ NPT as per ASME B1.20.1 taper pipe thread
- ⦿ All condensate pots are factory tested fully prior to shipment
- ⦿ Standard material of construction: 316 SS, 304 SS, Carbon steel
- ⦿ Pipe schedule: 40, 80, 160, XXS seamless steel
- ⦿ Variety of end connections available

Materials of Construction

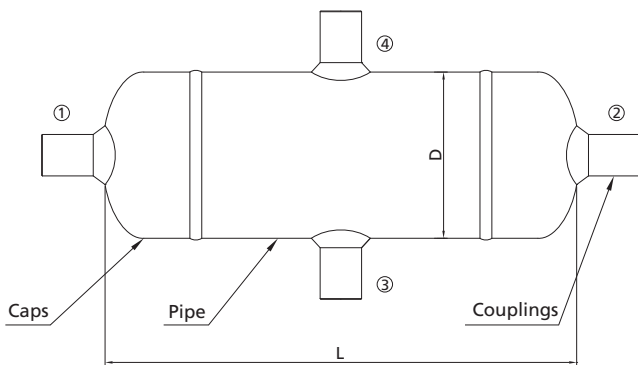



Material	Pipe	Cap
316 SS	TP316/A312	F316/A182
321 SS	TP321/A312	F321/A182
304 SS	304 SS/A312	F304/A182
CS	A106	A105
316L SS	TP316L/A312	F316L/A182
304L SS	TP304L/A312	F304L/A182

Dimensions

Dimensions are for reference only and are subject to change.

Pipe	Ø D, in (mm)	L, in (mm)	Capacity (L)
NPS 3	3.50 (88.9)	8.46 (215.0)	0.8
NPS 4	4.50 (114.3)	14.2 (360.0)	2.6

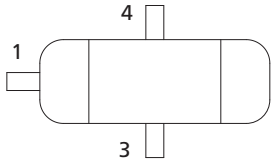
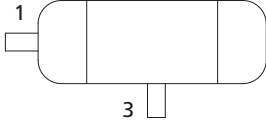
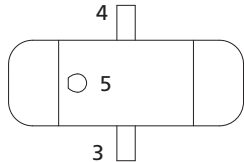
Configuration

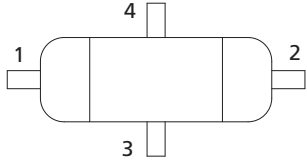
Designator	Schematic	Designator	Schematic
2A		3B	
2B		3C	
3A		4A	

Ordering Number Description

SS - CP - 36 - 4A - FNS8 - MTS14 - MTB12 - SF2

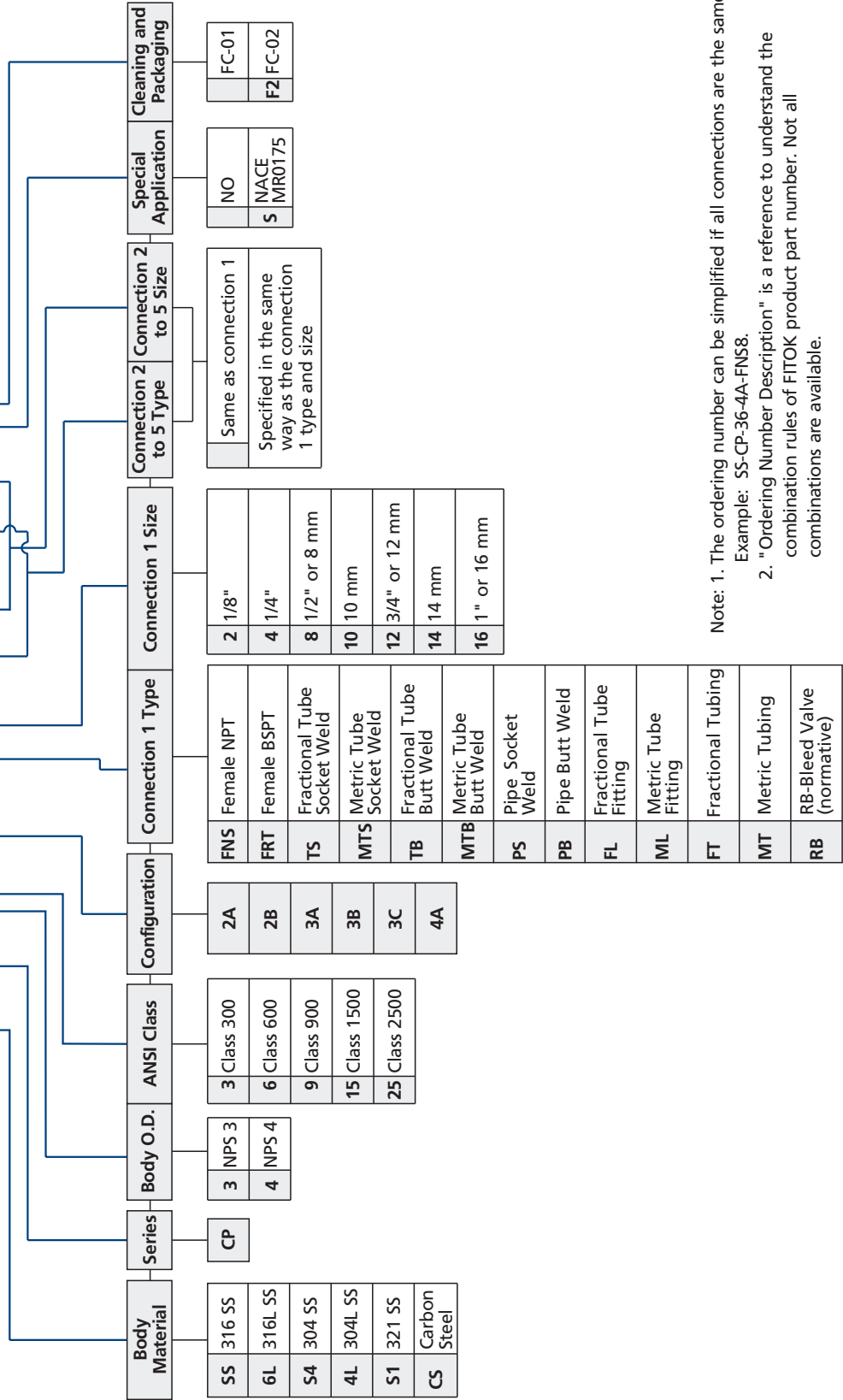

- Note: 1. The ordering number can be simplified if all connections are the same.
 Example: SS-CP-36-4A-FNS8.
 2. "Ordering Number Description" is a reference to understand the combination rules of FITOK product part number. Not all combinations are available.

Vessels

Features

- ⦿ Suitable for application with water, oil or gas
- ⦿ Chambers are made from seamless pipe and weld flat covers
- ⦿ Full-penetration gas tungsten arc -weld construction to ensure great strength and leak-tight performance
- ⦿ Five pressure ratings available

Technical Data

- ⦿ Working pressure up to: Class 2500 as per ASME B16.34
- ⦿ Socket weld connection as per ASME B16.11
- ⦿ Butt welding ends as per ASME B16.9
- ⦿ NPT as per ASME B1.20.1 taper pipe thread
- ⦿ All vessels are factory tested fully prior to shipment
- ⦿ Standard material of construction: 316 SS, 304 SS, Carbon steel
- ⦿ Pipe schedule: 40, 80, 160, XXS seamless steel
- ⦿ Variety of end connections available

Materials of Construction

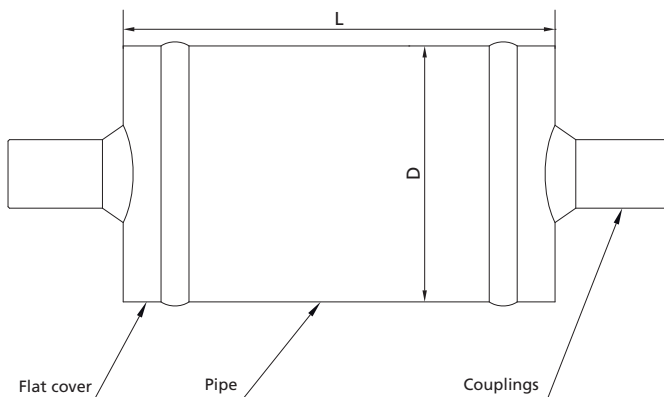

Material	Pipe	Flat cover
316 SS	TP316/A312	F316/A182
321 SS	TP321/A312	F321/A182
304 SS	304 SS/A312	F304/A182
CS	A106	A105
316L SS	TP316L/A312	F316L/A182
304L SS	TP304L/A312	F304L/A182

Dimensions

Dimensions are for reference only and are subject to change.

Pipe	Ø D, in (mm)	L, in (mm)
NPS 3	3.50 (88.9)	5.90 (150.0)
NPS 4	4.5 (114.3)	

Configuration

CV1

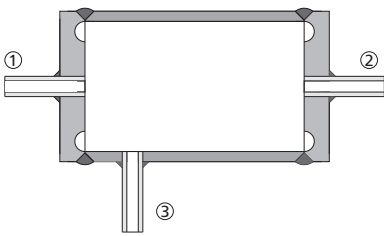

SV1

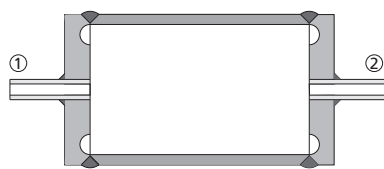

IV1

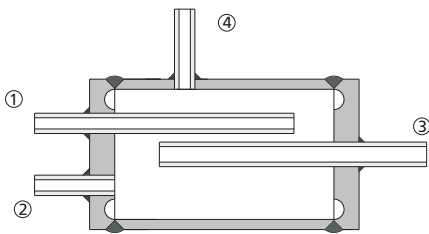

IV2

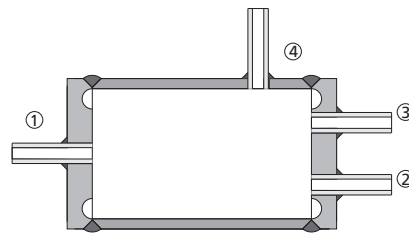

IV3

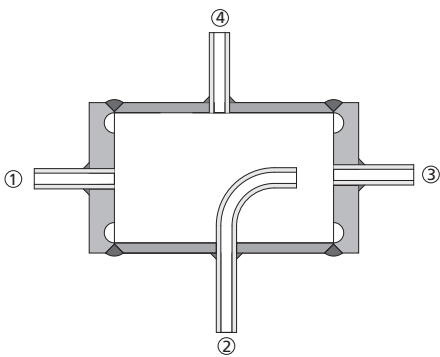

IV4

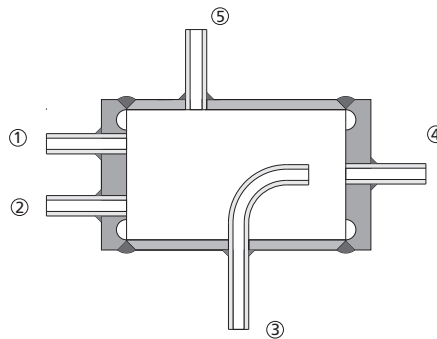

Ordering Number Description

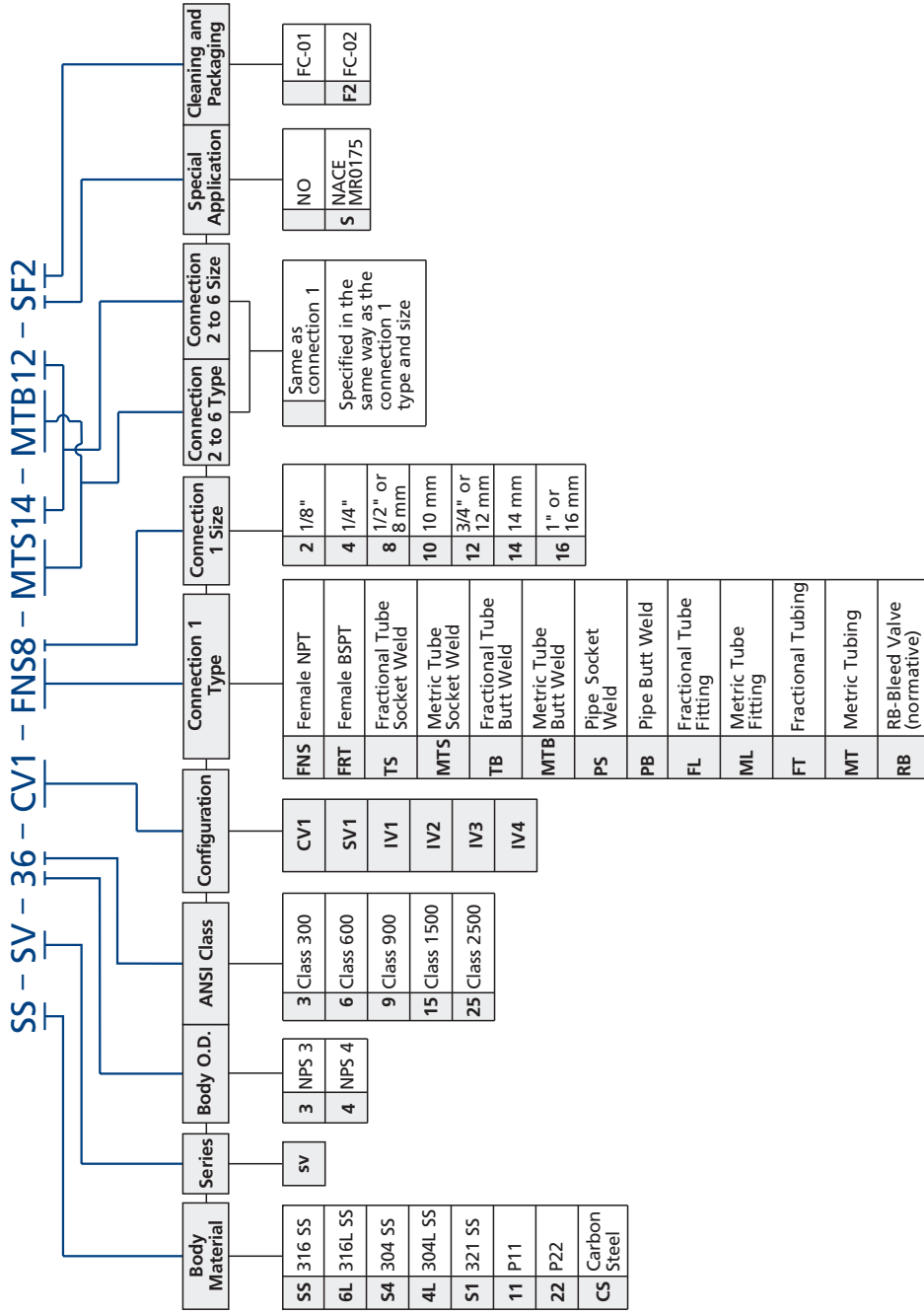

Note: 1. The ordering number can be simplified if all connections are the same.

Example: SS-SV-36-CV1-FNS8.

- "Ordering Number Description" is a reference to understand the combination rules of FITOK product part number. Not all combinations are available.

FITOK Group

FITOK GmbH (Headquarter)

Sprendlinger Landstr. 115, 63069 Offenbach am Main, Germany
Tel.: +49 69 8900 4498 Fax: +49 69 8900 4495

FITOK, Inc.

13843 North Promenade Blvd., Suite 750, Stafford, Texas 77477, USA
Tel.: +1 281 888 0077 Fax: +1 281 582 4051

FITOK Incorporated

Block C, Zone E, Yingtai Industrial Park, Dalang Street,
Longhua District, Shenzhen, 518109, China
Tel.: +86 755 2803 2500 Fax: +86 755 2803 2619

FITOK Middle East Oil Equipment Trading LLC

208-209, Makateb Building, P.O.Box 185412, Airport Road, Deira, Dubai, UAE
Tel.: +971 4 2959 853 Fax: +971 4 2959 854

info@fitokgroup.com
www.fitokgroup.com

FK-IC-GC-01-EN-170505